



MRD-1P™

INDUSTRIES, INC. Radar Presence Sensor



Operating Instructions

The MRD-1P radar presence sensor is used to indicate the presence of a vehicle or person in the vicinity of a barrier arm. It does not discriminate between people and vehicles. It can detect over a range of 1 – 30 ft (0.3 – 9.1 m), with the maximum detection distance adjustable via pushbuttons. The sensor will ignore any objects beyond the detection distance. The sensor is extremely accurate, measuring distance to within 0.04" (1 mm). The microwave beam is unaffected by rain, snow, ice, fog, or sunlight. It features Form C relay outputs for presence detection as well as solid-state relay outputs for pulse-on-entry/ pulse-on-exit signaling. It has a full-featured menu for further customization, accessed using the pushbuttons and a 3-digit display.

Cautions and Warnings



This product is an accessory or part of a system. Install the MRD-1P according to instructions from the barrier arm operator manufacturer. Comply with all applicable codes and safety regulations.

Specifications

Operating Range	1 ft (0.3 m) to 30 ft (9.1 m)
Operating Frequency	61 GHz
Power	6-40 VDC, 12-24 VAC
Max Current (24 VDC input)	40mA RMS
Max Current (24 VAC input)	150mA RMS
Surge Protection	Thermal fuse, MOV
Relay 1 Output Operation	Close on Presence, Open on Presence (N.C., COM, N.O.) <i>2.0A max</i>
Relay 2 Output Operation	Pulse on Entry, Pulse on Exit (N.C., COM, N.O.) <i>0.7A max</i>
Response Time from Power-up	< 250ms
Update Rate	30ms
Operating Temperature	-40° to 140°F (-40° to 60°C)
Dimensions (L x W x H)	5.1" (130 mm) x 3.15" (80 mm) x 5.5" (140 mm)
Ball Joint Mount Conduit Thread	½ Inch NPT

Relay Outputs

- **Presence:** Relay 1 acts as a presence output. The NC terminal is closed when no obstruction is present and opens when an obstruction is detected. The NO terminal is open when no obstruction is present and closes when an obstruction is detected. The relay hold time is configurable. *Note: Changing Fail Safe Mode reverses relay sense.*
- **Pulse:** Relay 2 provides pulsing functions. It can be configured for Pulse on Entry, Pulse on Exit, or Off (no pulse). The pulse time is configurable as 1 second or 0.5 seconds. The contact labels indicate the non-pulse state; for example, NC is connected to COM when no pulse is occurring and opens momentarily for the pulse.

Installation

- Deactivate the barrier arm prior to and during sensor installation.
- **Location:** Mount the sensor under the barrier arm (safety zone), before the arm (entry zone), or after the arm (exit zone), aiming across the lane of traffic. See page 4 for a detailed discussion of sensor locations. You may need to raise or lower the sensor to get the best performance. Recommended mounting height is 22" – 28" (46 cm – 56 cm). The sensor should be mounted high enough to detect vehicles with high ground clearance such as trucks.

When locating the sensor in your installation, visualize the beam to ensure it will be kept clear of unwanted obstructions. The beam is cone-shaped. The figure below (not to scale) shows the beam in 3 dimensions at distances of 1 ft (0.3 m), 15 ft (4.6 m), and 30 ft (9.1 m):

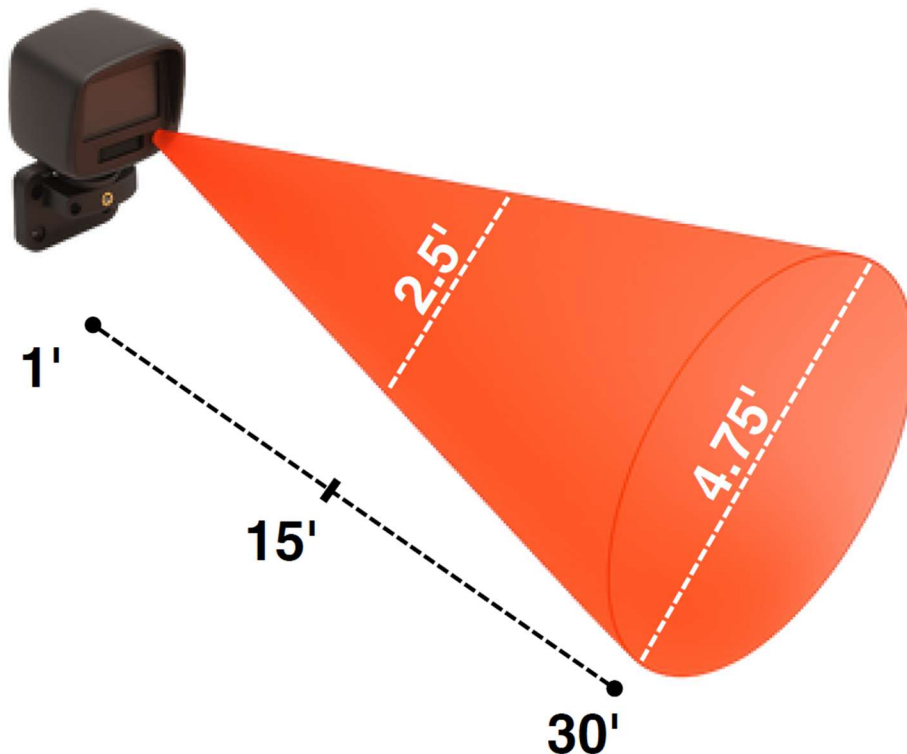

Example Beam, Defined by Detecting a Person
(not to scale)



The MRD-1P does not detect objects closer than 1 ft (0.3 m). Objects closer than 1 ft may interfere with proper operation.

In reality, the edges of the beam are not sharp. They fade gradually into space, getting weaker as the distance from the beam center increases. This means that larger objects will be detected further outside of the beam center than smaller objects. An illustration of this is shown below:

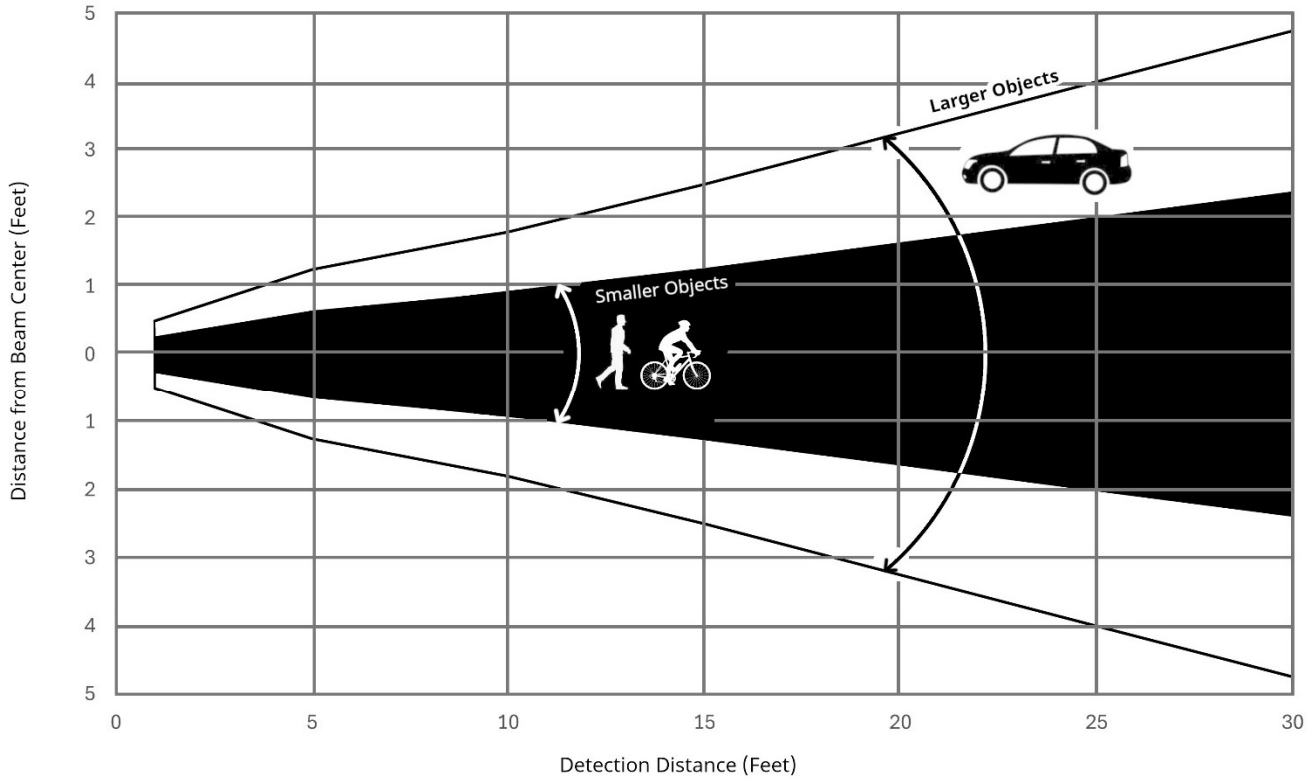

Detection Zone for Various Objects (Top View)
(not to scale)

The numbers shown are estimates, based on the sensor's default settings. Use the following beam width table when planning your installation:

Distance	Beam Width for a Person	Beam Width for a Car
1 ft (0.30 m)	0.5 ft (0.15 m)	1 ft (0.30 m)
5 ft (1.52 m)	1.25 ft (0.38 m)	2.5 ft (0.76 m)
10 ft (3.05 m)	1.8 ft (0.55 m)	3.6 ft (1.10 m)
15 ft (4.57 m)	2.5 ft (0.76 m)	5.0 ft (1.52 m)
20 ft (6.10 m)	3.25 ft (0.99 m)	6.5 ft (1.98 m)
25 ft (7.62 m)	4 ft (1.22 m)	8 ft (2.44 m)
30 ft (9.14 m)	4.75 ft (1.45 m)	9.5 ft (2.90 m)

The beam width is narrower for a person than for a car because a person produces a weaker radar reflection than a car. Another way of understanding this is that as a car approaches the sensor, it will be detected sooner than a person would be. A large truck will be detected even sooner.



The MRD-1P cannot discriminate between a person and a vehicle; it will signal presence regardless of the object.

Sensor Location: Safety Zone (Keep Arm Up)

The typical sensor location is directly underneath the arm in order to detect objects in the travel path of the arm, for safety. This location typically works well since the radar waves travel along the arm and don't reflect off of it. This makes the arm "invisible" to the sensor.

When an obstruction is present in the path of the arm, the sensor detects it and reports presence, keeping the arm up. See the figure on the right (not to scale) for a top view of the application.

Avoid angling the sensor up toward the arm at too steep of an angle to ensure it doesn't detect the arm.

See pages 5-6 for more details on this type of installation.

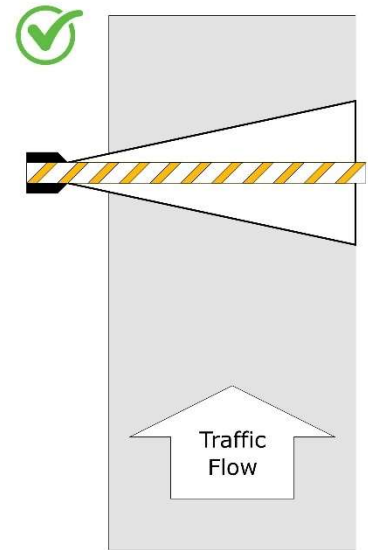

*Safety Zone
Application Example*

Sensor Location: Entry Detection (Raise Arm)

For entry detection, locate the sensor *before* the arm with respect to the flow of traffic.

Avoid angling it toward the arm since the radar waves may reflect back to the sensor.

See the examples below (not to scale) of good and bad placement:

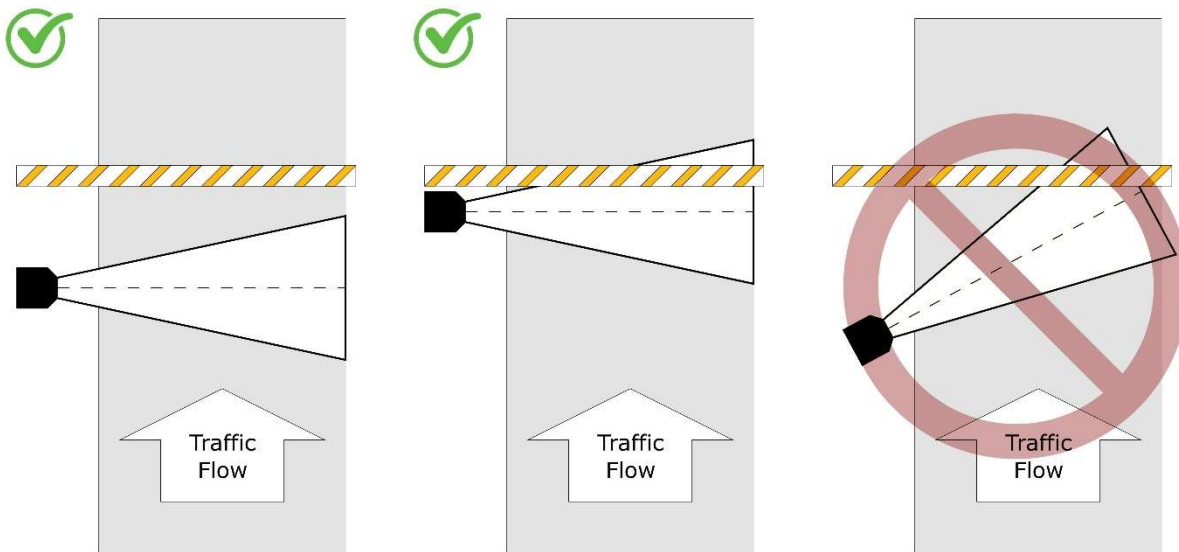

Entry Detection Application Examples

As shown, the distance from the sensor to the arm is less of a concern than the *angle of the sensor to the arm*. You may need to experiment with the sensor location to ensure it doesn't detect the arm.

Sensor Location: Exit Detection (Lower Arm)

For exit detection, locate the sensor *after* the arm with respect to the flow of traffic. Avoid angling it toward the arm since the radar waves may reflect back to the sensor. See the examples below of good and bad placement:

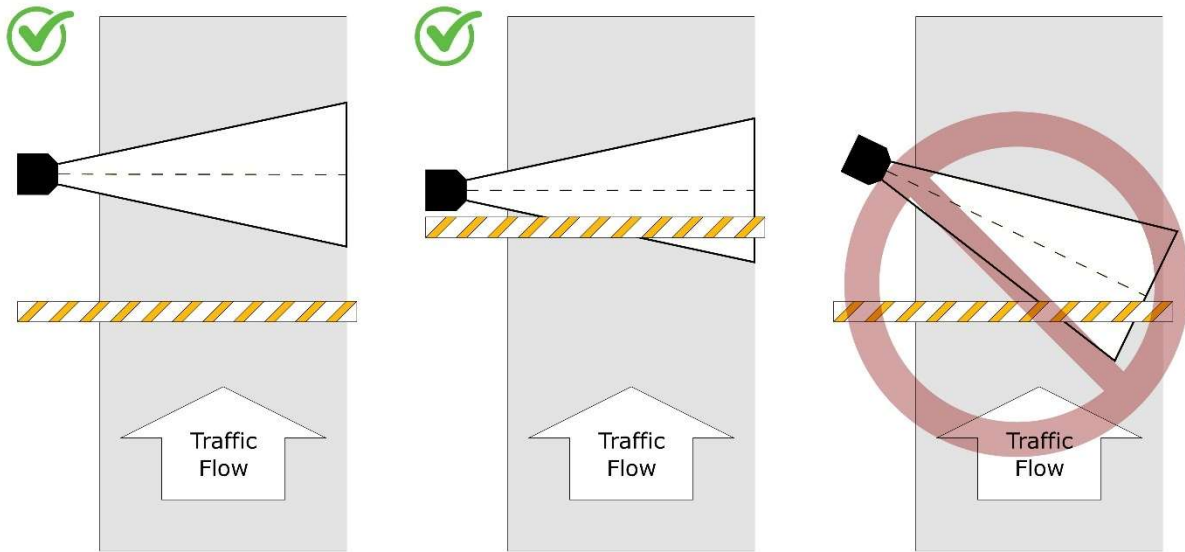

Exit Detection Application Examples

As shown, the distance from the sensor to the arm is less of a concern than the *angle of the sensor to the arm*. You may need to experiment with the sensor location to ensure it doesn't detect the arm.

Side Views of Installations

The sensor's beam should be parallel to the ground or angled slightly upward to avoid reflections off curbs. The figure below shows the **ideal installation**:

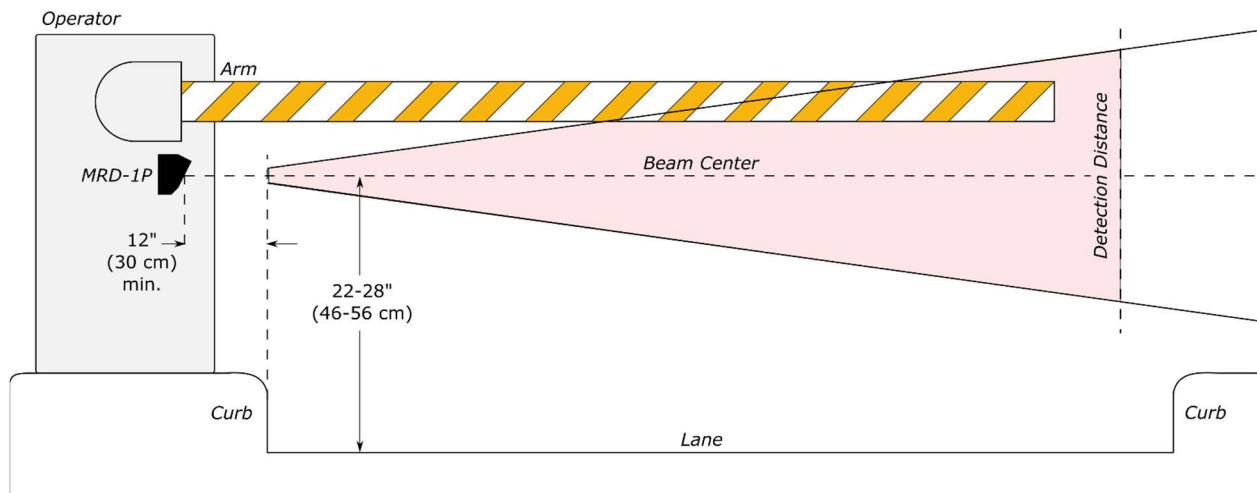

Side View of Ideal Installation (not to scale)

In the figure, note the following:

1. Beam center is parallel to the arm
2. Detection distance is set to just beyond the reach of the arm

A **problematic installation** is shown below. **This should be avoided:**

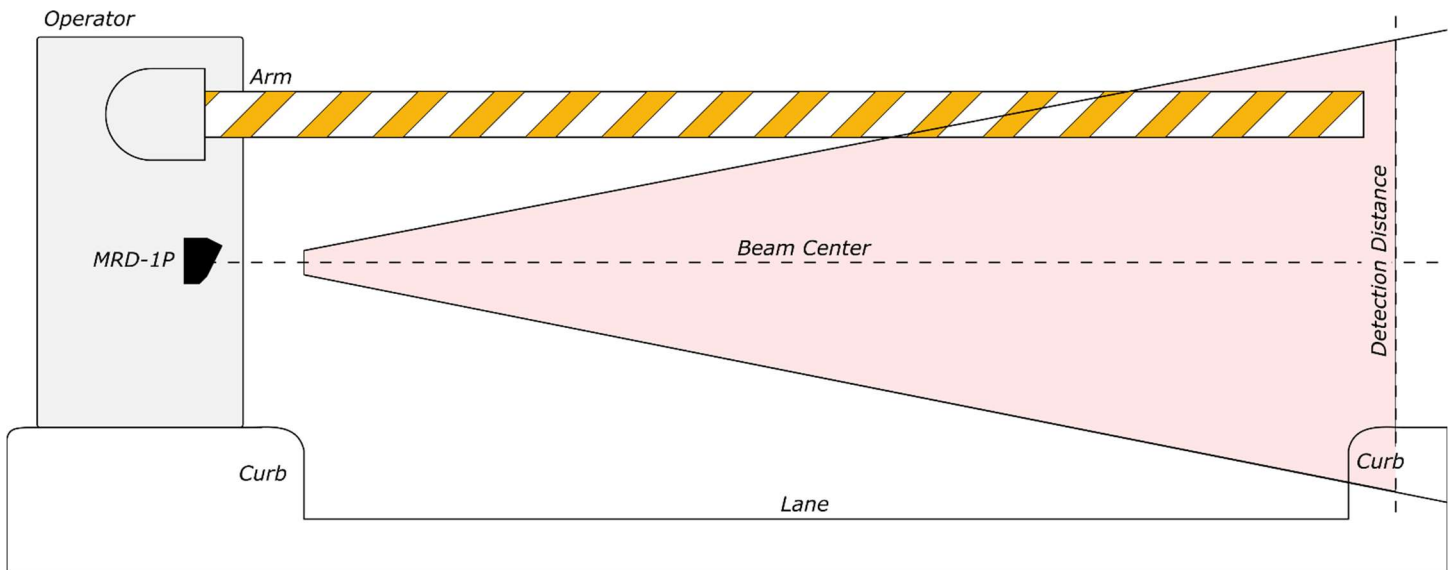

Side View of Problematic Installation (not to scale)

In the figure, note the following:

1. The arm is longer, forcing the installer to increase the **detection distance** to ensure safety.
2. The MRD-1P beam is wider, likely due to the **threshold** being lowered (this setting is discussed later in this document).
3. The sensor is mounted lower than in the previous figure, for unknown reasons.
4. Because of items 1-3 above, the far curb now falls within the sensor's detection zone. The sensor will likely detect the curb, preventing the arm from operating.

The following are possible solutions to fix this problem:

1. Mount the MRD-1P higher so that the curb falls outside of the beam. Make sure that the sensor doesn't detect the arm since it will be closer to it in the new location.
2. Install a shorter barrier arm on the operator. Then decrease the MRD-1P's detection distance so that it will ignore the curb.
3. Increase the threshold of the MRD-1P. This will narrow the beam. Make sure that the higher threshold still provides reliable detection of the smallest expected targets at the furthest expected distance. **Threshold** is discussed on pages 13-14.

Once the location is chosen, proceed with the installation as follows:

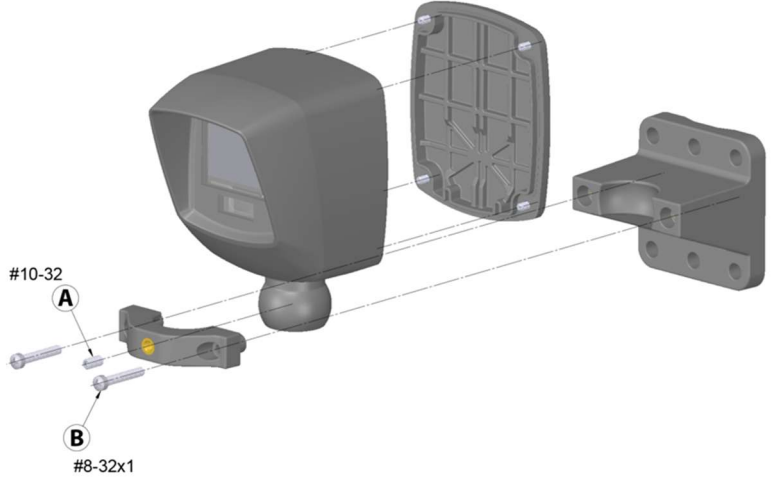
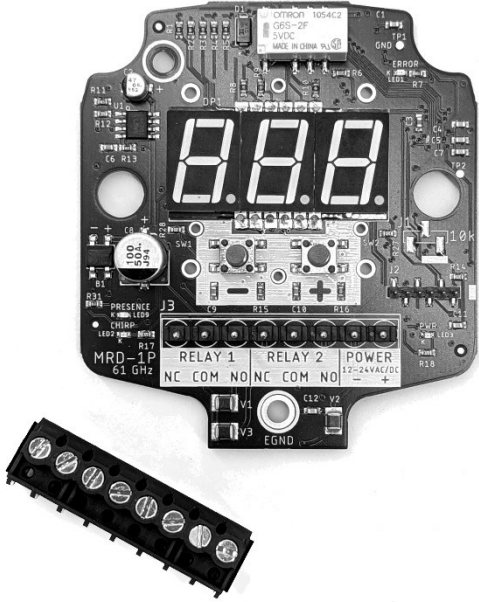
<p>1. Check the instruction manual of the barrier arm operator to determine the necessary wiring for the MRD-1P relay outputs.</p>	
<p>2. Unscrew the four back cover screws, then remove the back cover. Feed wiring through the ball joint opening.</p> <p>The wiring to the enclosure should enter via a watertight fitting such as a strain relief or ½ inch NPT thread watertight conduit connector.</p>	
<p>3. Wire the sensor according to the desired method (normally closed presence, pulse on exit, etc.). Do not wire with power applied.</p>	
<p>The MRD-1P has a detachable screw terminal block for easier wiring. Remove it while connecting wires, then plug it back in properly and secure it.</p>	

Terminal Block Connection	Description
Relay 1 NC	Presence relay normally closed contact (in Fail Open mode)
Relay 1 COM	Presence relay common contact
Relay 1 NO	Presence relay normally open contact (in Fail Open mode)
Relay 2 NC	Pulse relay normally closed contact
Relay 2 COM	Pulse relay common contact
Relay 2 NO	Pulse relay normally open contact
Power -	12-24 VAC/DC power supply, V-
Power +	12-24 VAC/DC power supply, V+

EGND	Earth Ground. This optional wire-to-screw connection may help mitigate EMI issues.
------	--

4. To mount the sensor, first secure the bracket clamp base (ITEM C) to the mounting surface. The mounting for a flat surface, such as a square tube or wall is shown below.

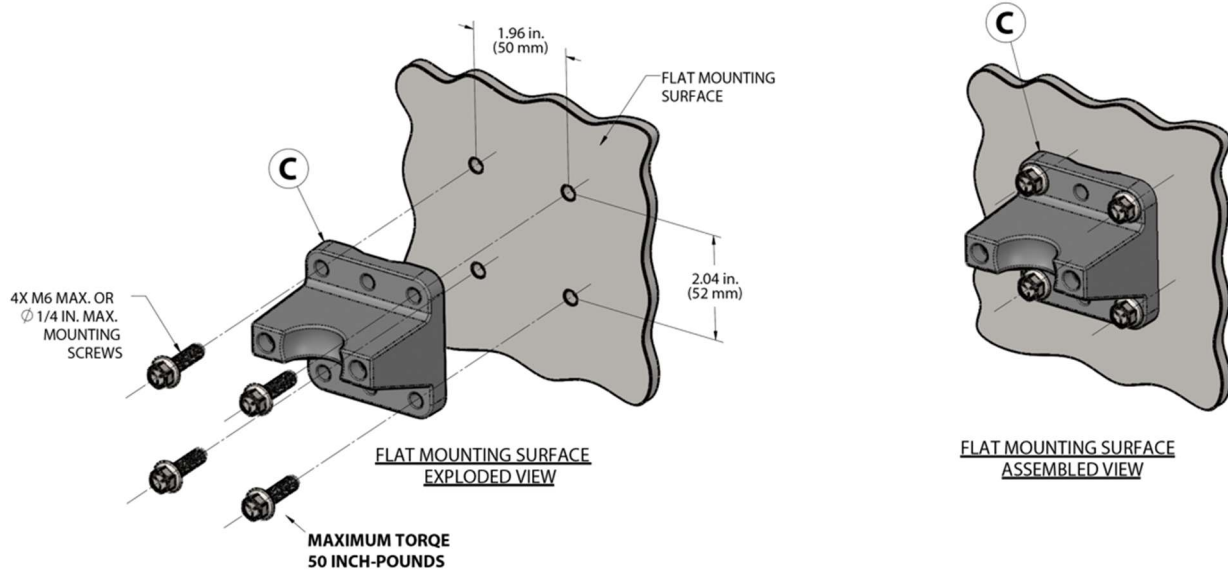

The mounting for a curved surface, such as a pole, is shown below:

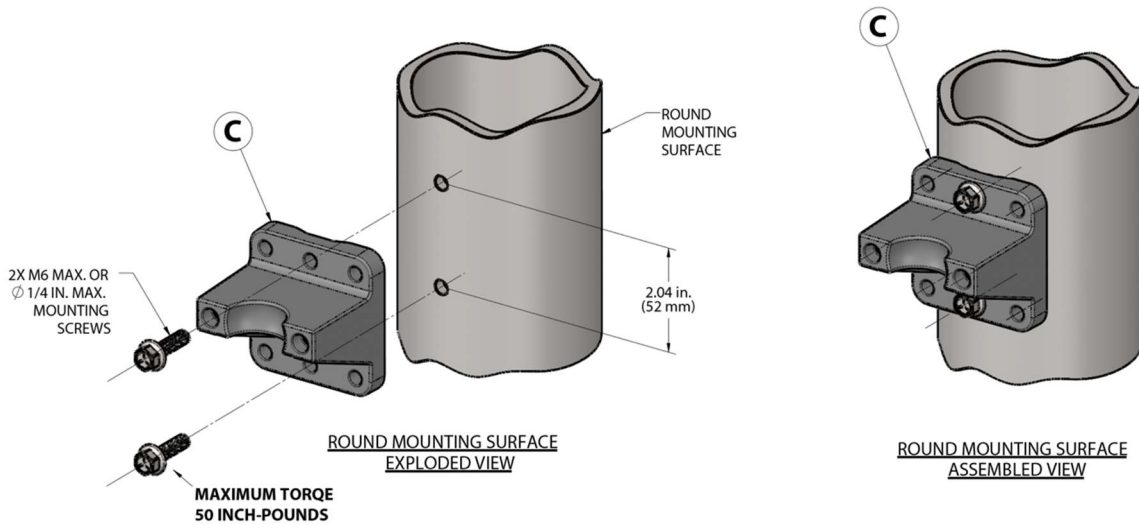

Note the different screw locations for a flat vs. curved surface. The mounting patterns for flat and curved surface are shown below.

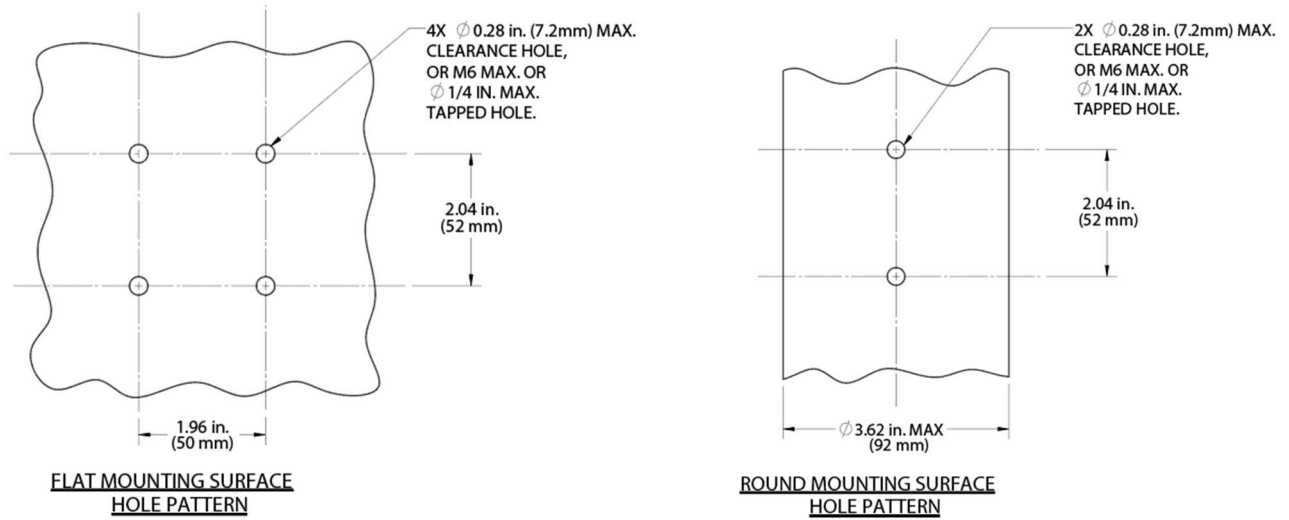

Use the included Bracket Mounting Template to drill holes for mounting.

5. After mounting the bracket base, attach the sensor and bracket clamp. Tighten the two bracket clamp screws (ITEM B) to secure the sensor, but leave them loose enough for the sensor to swivel using the ball joint while aiming the sensor.
6. After all wiring and mounting is complete, apply power to the sensor. Leave the back cover off.

A diagram of the circuit board is shown below:

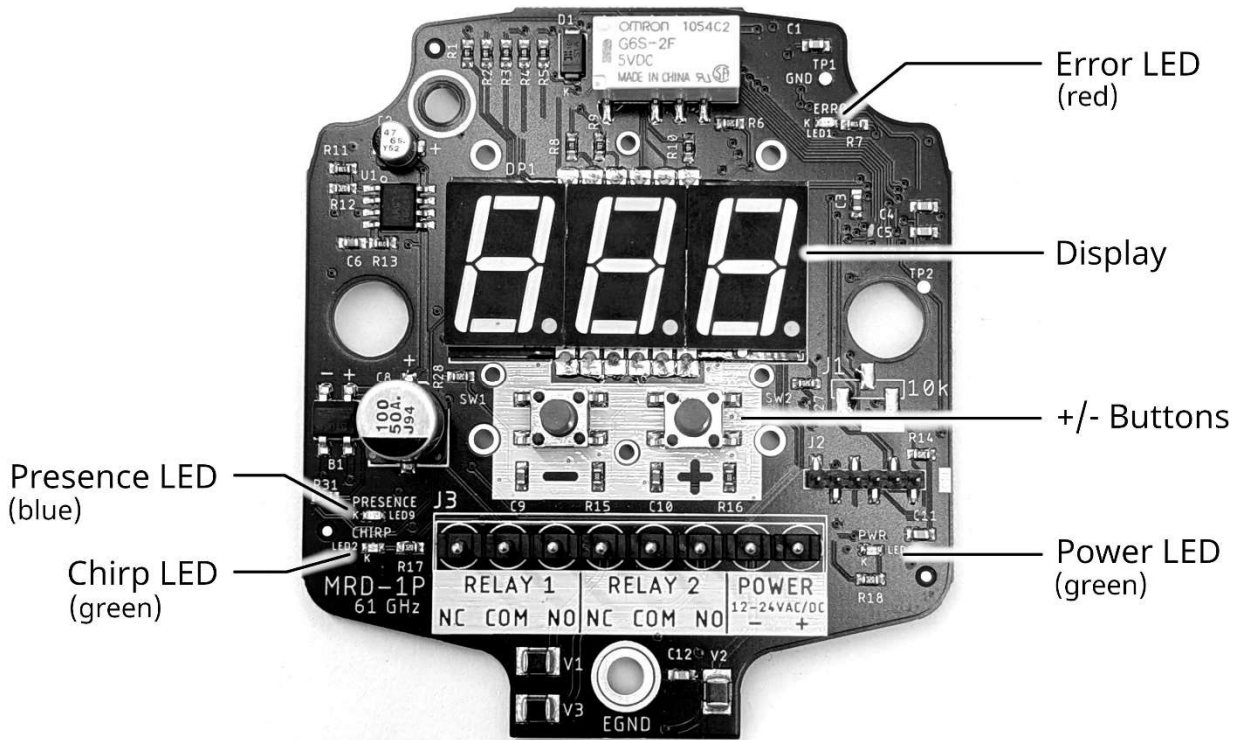

Ensure that the Power and Chirp LEDs are on. The Error LED should be off. The Presence LED lights when an obstruction is detected within the distance (in feet) shown on the display. If any LEDs are not lit as expected or there is an error code on the display such as "E1" or "E2", see the Troubleshooting section at the end of this document.

7. The default detection distance is 10.0 ft (0.3 m). It is shown on the display. To increase the detection distance press the "+" button. To decrease the detection distance press the "-" button. For every press the detection distance will change by 0.5 ft (0.15 m). The new detection distance is immediately saved on each button press even if power is lost. The detection distance can be adjusted from 1.5 ft – 30 ft (0.46 m - 9.14 m). **Any obstruction that is detected at a distance equal-to-or-less-than this setting will trigger Relay 1 (Presence) and Relay 2 (Pulse, if used).**

Note: The display will turn off after 15 minutes of inactivity. To turn it back on, simply press either button.

The sensor features two front-facing LEDs: blue for Presence and red for Pulse. They are shown below:



8. Test the Presence feature:



Make sure the barrier arm is safely locked in the up position during this test!

With nothing in the sensor's beam the Presence LED should be off. Stand outside the beam and wave your hand into the beam (make sure your hand is at least 1 ft away from the sensor). You should see the blue Presence LED light as your hand passes in front of the sensor and turn off as your hand leaves the beam. If so, continue to Step 9.

If the Presence LED is stuck on all the time, the sensor sees something in the beam. Try decreasing the detection distance until the Presence LED turns off. You may also need to adjust the alignment of the sensor to achieve the desired detection zone. If you cannot get the Presence LED to turn off, see the Troubleshooting section.

9. Test the Pulse feature, if using:



Make sure the barrier arm is safely locked in the up position during this test!

Again wave your hand in front of the sensor. As your hand leaves the beam the red Pulse LED should turn on momentarily, then turn off. This is the correct behavior for Pulse on Exit mode, which is the default setting. See the User Settings Menu section to change the Pulse mode.

10. If you are only using the Presence feature you can now test the correct operation of the barrier arm, provided you have correctly configured your operator. Unlock the barrier arm so that it can move and issue a "down" command. When an obstruction enters the beam the arm should reverse. With no obstruction, the arm should travel all the way down and stay down. If your system does not operate as intended, see the Troubleshooting section.

11. If you are satisfied with the operation of your system, you can close up the sensor. Make sure the back cover gasket is present, the cover is properly seated, and the cover screws are tight. Tighten the two bracket clamp screws (ITEM B) until the sensor no longer moves with your hand (use hand tools only). Tighten set screw (A) last, and only rotate ½ turn after feeling resistance. (3/32" Allen wrench is required). If the sensor doesn't move with your hand then the clamp is sufficiently tightened.

User Settings Menu

The MRD-1P provides a user settings menu to further configure and fine-tune operation of the sensor, if needed. The menu is accessed using the +/- buttons and 3-digit display. The various menu screens are shown below, followed by a discussion of menu settings and usage.

Setting	Options (* = Default)		
Presence Hold Time 	Infinite *	4 minutes	
			
Pulse Mode	Pulse on Entry	Pulse on Exit *	Off
			
Pulse Time	0.5 seconds *	1 second	
			
Fail Safe Mode	Fail Open *	Fail Closed	
			
Stealth Mode	On	Off *	
			
Transmit Power	Value of 1-31 *Default: 31		
			
Threshold	Value of 30-45 (dB) *Default: 35		
			
Off Delay	Value of 0.1 – 4.0 (seconds) *Default: 1.0		
			

To access the menu, press and hold both buttons for 3 seconds, then release when you see "Ht". When using the menu, each screen will display the title of the setting for one second (the "Menu Title" column in the table above), and then the setting itself will be displayed (the "Allowed Settings" columns). To change the setting, press the "-" button. This will cycle through the available options. To go to the next screen, press the "+" button. To exit the menu and save all settings, press and hold both buttons for 3 seconds. At that point the sensor will reset and the detection distance will be displayed. All settings take effect immediately.

Presence Hold Time ("Ht"): Controls whether Relay 1 stays energized forever as long as an obstruction is present or if it de-energizes after a length of time. If set to "Infinite", (most common) the relay will stay energized for as long as the obstruction is present. If set to "4 minutes" it will de-energize after 4 minutes with an obstruction present.

Pulse Mode ("PLS"): Controls what kind of pulse Relay 2 outputs. If "Pulse on Entry", Relay 2 pulses for Pulse Time seconds when an obstruction enters the detection zone. If "Pulse on Exit", Relay 2 pulses for Pulse Time seconds when an obstruction exits the detection zone. If "Off", Relay 2 does not output any pulse.

Pulse Time ("Pt"): Sets the duration of the Relay 2 pulse, in seconds. Options are 1 second or 0.5 seconds. If **Pulse Mode** is set to "Off" this setting has no effect.

Fail Safe Mode ("FS"): Defines the operation of Relay 1 should a power loss or sensor fault occur. If "Fail Open", the relay will change state during a loss of power or sensor fault (NC will open, NO will close). If "Fail Closed", the relay will function opposite what is written on the PCB. When powered on and no presence, NO will be closed and NC will be open. The relay WILL NOT change states during loss of power so the gate stays closed during power loss.

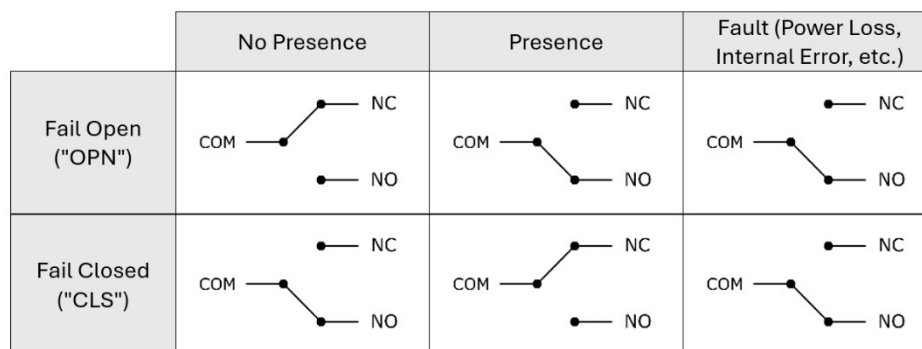

Stealth Mode ("StL"): In Stealth Mode, the Presence LED turns off after 30 seconds of sustained Presence. Stealth Mode is only useful in non-standard applications where Presence is expected to persist for long periods of time and where the sensor should be hidden. Selecting "On" enables Stealth Mode and "Off" disables it.

Transmit Power ("tPr"): Sets the strength of the radar signal from 1 (weakest) to 31 (strongest). Generally the default setting of 31 is best. If you find that the sensor is interfering with another device (not common), lowering this setting may help.

Threshold ("thr"): Sets the detection threshold from 30 (most sensitive) to 45 (least sensitive). The lower the number, the easier it will be for the sensor to detect an object. EMX recommends using the highest value that works reliably in your application since lower thresholds may lead to false triggers. Increasing the threshold can help combat interference from other devices. See p. 14 for more tips on setting the threshold.

Off Delay ("dLy"): Sets the delay, in seconds, from when the beam is unblocked to when the Presence output is deactivated. Adjustment range is 0.1 – 4.0. The adjustment resolution is 0.1 seconds below a value of 1 second and 0.5 seconds from 1 second to 4 seconds.

Reduce "Dropouts" and "Chatter" with Off Delay

If you find that the Presence relay is "dropping out" of Presence while objects are still in the detection zone, you may be able to remedy this by increasing the **Off Delay** setting. The default setting is 1.0 seconds but increasing it further will help reduce dropouts. Conversely, decreasing the Off Delay will make the sensor respond more quickly when objects leave the detection zone but may lead to more dropouts. Extremely low values of Off Delay may also lead to "chattering" (rapid on-off cycling) of the Presence relay. If you experience chatter, increase the Off Delay.

Tailgater "Cheat" Zone

A common challenge in barrier arm safety applications is preventing unwanted entry by tailgating vehicles. These vehicles "cheat" by entering the safety sensor's beam too soon after the previous vehicle exits, which either keeps the arm up or reverses it. The diagram below shows the two key dimensions that define the "cheat zone":

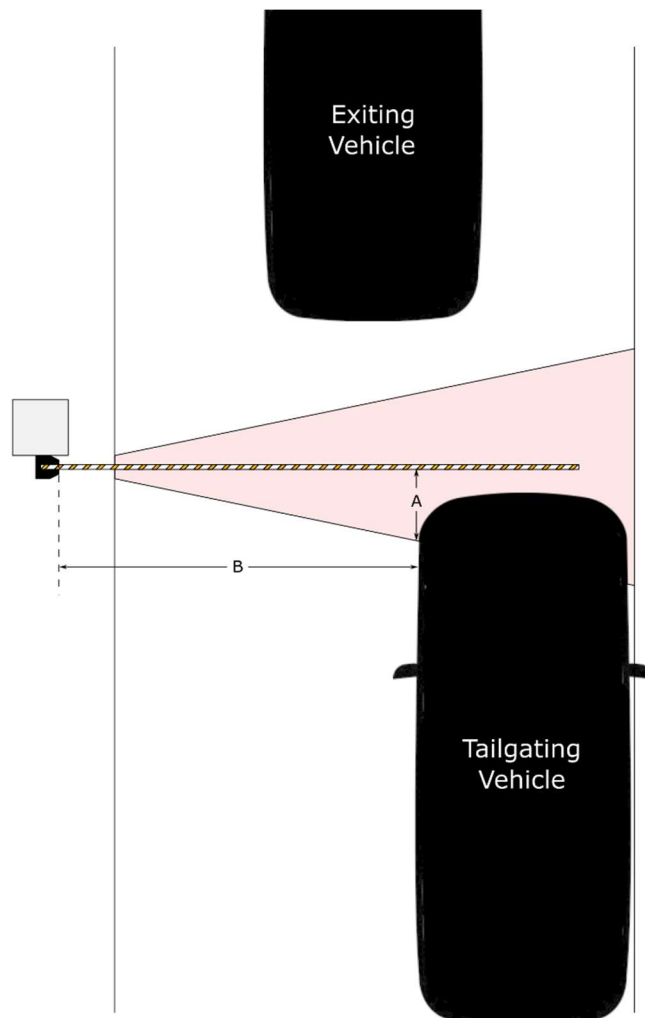

Tailgating Cheat Zone (not to scale)

In the diagram, dimension B represents the distance from the broad side of the tailgating vehicle to the MRD-1P. Dimension A represents the distance from the beam center; at distances greater than this the tailgater will not be detected by the MRD-1P. **"A" is not half the beam width; it is a larger distance and was determined through testing.** The larger "A" becomes, the greater ability the tailgater has to cheat by keeping the arm up. As "B" increases, "A" also increases, so the worst case scenario is when the tailgating vehicle is as far away from the sensor as possible. The following table lists dimensions "A" for various dimensions "B" measured using the default sensor settings:

Tailgater Distance from MRD-1P (B)	Distance from Beam Center for No Detection (A)
1 ft (0.30 m)	1.00 ft (0.30 m)
2 ft (0.61 m)	1.25 ft (0.38 m)
3 ft (0.91 m)	1.50 ft (0.46 m)
4 ft (1.22 m)	1.75 ft (0.53 m)
5 ft (1.52 m)	2.25 ft (0.69 m)
6 ft (1.83 m)	2.50 ft (0.76 m)
7 ft (2.13 m)	2.75 ft (0.84 m)
8 ft (2.44 m)	3.50 ft (1.07 m)
9 ft (2.74 m)	3.63 ft (1.11 m)
10 ft (3.05 m)	3.88 ft (1.18 m)
11 ft (3.35 m)	4.25 ft (1.30 m)
12 ft (3.66 m)	4.63 ft (1.41 m)
13 ft (3.96 m)	4.25 ft (1.30 m)

If you experience problems with Tailgaters, it may help to lower the Off Delay, which will decrease the time it takes the arm to lower after a vehicle leaves the beam. Also, you may be able to decrease "A" slightly (by inches) by adjusting the Threshold.

Adjusting the Threshold

The threshold determines how weak of an echo will trigger a Presence signal. The echo must be above the threshold level for the sensor to report Presence. In general, increasing the threshold makes the sensor less sensitive and decreasing the threshold makes the sensor more sensitive. EMX recommends leaving the threshold at its default setting unless you experience persistent problems with dropouts or tailgating. You should try to adjust the location and alignment of the sensor as discussed in the Installation section before changing the threshold. You should also make sure that the Off Delay is set as high as your system can tolerate before adjusting the threshold. If you do wish to adjust the threshold, use the following guidelines:

If...	Then...
Tailgaters "cheat" the sensor too easily	Raise the threshold
Sensor triggers randomly with no vehicle present	Raise the threshold
Sensor doesn't detect vehicles reliably	Lower the threshold
Off Delay was lowered and now dropouts occur	Lower the threshold
Sensor has problems detecting smaller vehicles	Lower the threshold
Sensor has problems detecting vehicles far away	Lower the threshold

Factory Reset

To restore the sensor to its default settings:

1. Make sure the detection distance is displayed. If not, cycle power to the sensor.
2. Press and hold both +/- buttons for 10 seconds. During this time you will see the following:
 - a. After 3 seconds "Ht" is displayed.
 - b. After 3 more seconds, the display will begin flashing "dEF".
 - c. After 3 more seconds, the default detection distance ("10.0") will be displayed.
3. Release the buttons. The factory reset has been completed and all settings have been restored to their default values. These settings take effect immediately.

Note: Releasing the buttons at any time before the Factory Reset completes will abort the procedure.

The factory default settings are listed in the table below:

User Setting	Default Value
Detection Distance	10.0
Presence Hold Time ("Ht")	Infinite
Pulse Mode ("PLS")	Pulse on Exit
Pulse Time ("Pt")	0.5 seconds
Fail Safe Mode ("FS")	Fail Open
Stealth Mode ("StL")	Off
Transmit Power ("tPr")	31
Threshold ("thr")	35
Off Delay ("dLy")	1.0

Troubleshooting

Symptom	Possible Cause	Solution
Presence LED stuck on	Sensor sees the ground Obstruction in detection zone	Ensure sensor is not angled down and/or move sensor higher off the ground Ensure no columns, bollards, curbs, or other structures are in the sensor's detection zone
Presence falsely indicated when arm is lowered	Sensor beam is reflecting off the arm	If mounted below the arm, ensure arm has no flat surfaces facing the sensor. Remove flat surfaces or mount the sensor lower if possible.

<p>Presence falsely indicated when arm is lowered (cont'd.)</p>	<p>Sensor beam is reflecting off the arm</p>	<p>If mounted before or after the arm, ensure sensor is not angled toward the arm</p> <p>Ensure nothing is mounted to the arm that might reflect back to the sensor (no perpendicular surfaces)</p> <p>If sensor is angled upward, angle it slightly more downward.</p>
<p>Presence indicated erratically with no obstruction present</p>	<p>Threshold set too low (makes sensitivity high)</p>	<p>Increase the threshold ("thr")</p>
<p>Sensor detects unwanted obstructions out to its sides</p>	<p>Threshold set too low</p> <p>Transmit power set too high</p>	<p>Increase the threshold ("thr")</p> <p>Decrease the transmit power ("tPr")</p>
<p>Sensor does not detect objects reliably or drops out of detection while object is still present</p>	<p>Threshold set too high</p> <p>Off delay set too low</p> <p>Transmit power set too low</p>	<p>Decrease the threshold ("thr")</p> <p>Increase off delay ("dLy")</p> <p>Increase the transmit power ("tPr")</p>
<p>Presence indicated but operator does not respond</p>	<p>Faulty connection between sensor and operator control input</p> <p>Incorrect Fail Safe configuration</p> <p>Incorrect operator configuration</p>	<p>Verify all wires and terminal connections to operator</p> <p>Check the Fail Safe setting ("FS") to make sure the Relay 1 sense is correct and not inverted</p> <p>Refer to your operator's manual for configuration details</p>
<p>Display shows "E1"</p>	<p>One or more user settings is invalid</p>	<p>Adjust user settings (p. 12-13)</p> <p>Perform a Factory Reset (p. 15)</p>

Display shows "E2"	There is an internal error in the sensor	Contact EMX Technical Support
--------------------	--	-------------------------------

Warranty

EMX Industries, Inc. products have a warranty against defects in materials and workmanship for a period of two years from the date of sale to our customer.

Compliance

Note: This equipment has been tested and found to comply with the limits for a Class A digital device, pursuant to part 15 of the FCC Rules. These limits are designed to provide reasonable protection against harmful interference when the equipment is operated in a commercial environment. This equipment generates, uses, and can radiate radio frequency energy and, if not installed and used in accordance with the instruction manual, may cause harmful interference to radio communications. Operation of this equipment in a residential area is likely to cause harmful interference in which case the user will be required to correct the interference at his own expense.

Changes or modifications that are not expressly approved by EMX could void the user's authority to operate this equipment.