



CellOpener-365

GSM Access Control

With Yearly & Weekly Timer

Instruction Manual

This GSM access control system allows up to 2000 registered users to operate any garage door / gate using their phone with no cost for the call to the user. This simple to use access control system uses a GSM SIM card that must be activated upon installation. Simply dial the associated phone number for the SIM Card from any phone or mobile-phone and the gate will open without any cost of a call to you and with no limit of range. The CellOpener-365 also allows for an input contact to be used to trigger a custom-made SMS text message to a property manager letting him know that someone is at the gate or door.

In addition, the unit offers Weekly Timer and 365 Day Timer capability to offer maximum security and allow a property manager to prevent (or enable) the gate or overhead door from opening (or stay close) on certain days and times such as national holidays or special events. The current date and local time is automatically set via the GSM network so there is never a reason to even make adjustments for daylight savings time.

All the programming of the CellOpener-365 is done by simple SMS text commands. This feature allows programming to be done remotely from anywhere in the world making life easy for maintenance, security and HR staffs that need to enable or disable an individual person's access to a site within a second.

Specifications

Power	12V – 18V AC or DC
Standby Current-LEDs enabled	0.2A @ 12 VDC / 0.3A @ 24VDC
Standby Current-LEDs disabled	0.1A @ 12 VDC / 0.15A @ 24 VDC
Max Authorized Users	1600 Normal Users and 400 Special Users
Relay Contact Rating	5A @ 24V
Operating Temperature	Min -40°C / Max 65°C
Antenna Cable Length	3m' (118.2 inches)
Lead Cable Length	0.5m' (19.7 inches)

Wiring Connections

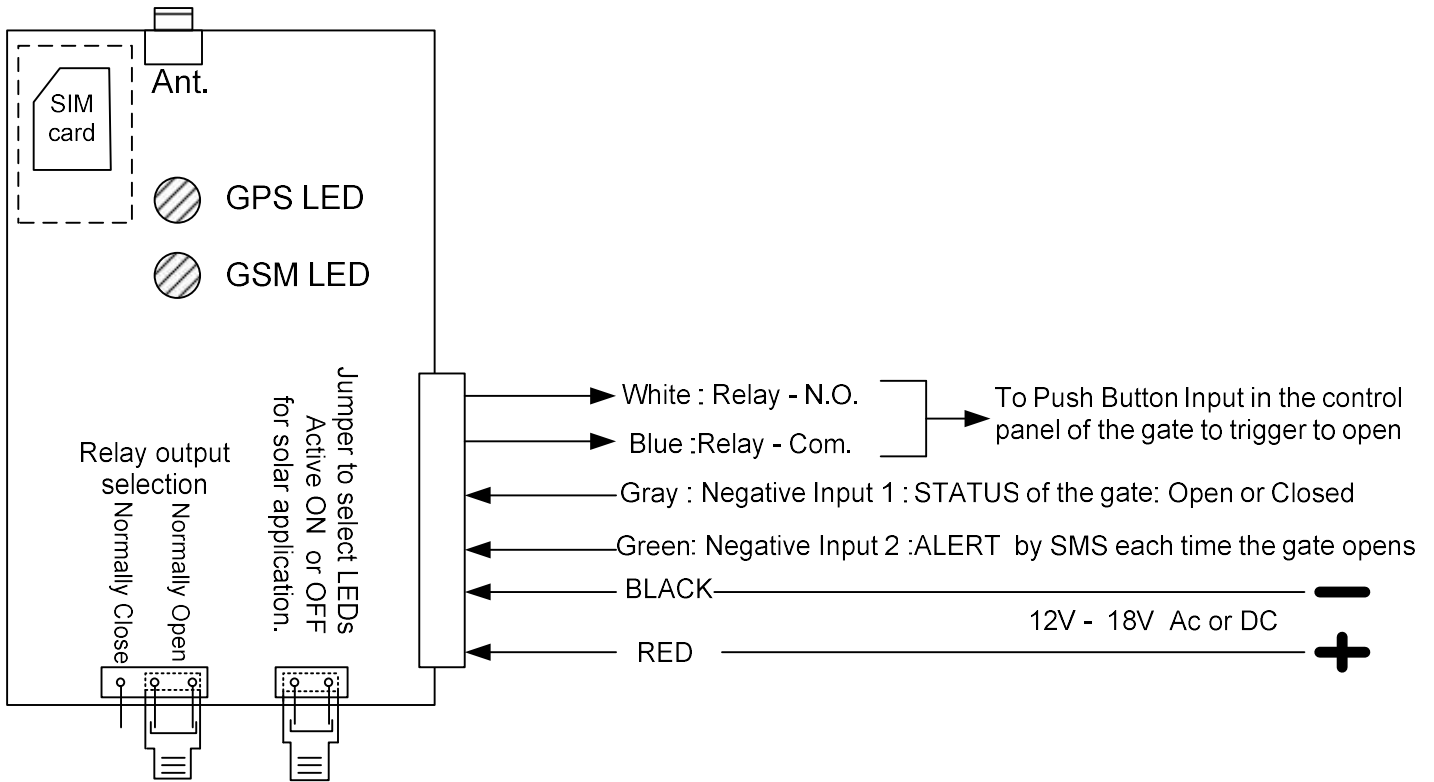

1. Power

Make sure to insert the SIM card and connect the Antenna before you power-up the unit.

Do not attach the unit's antenna to any metal surface.

The unit can operate with voltage between 12V to 18V AC or DC using the black and red wires. If DC power is used, the **BLACK** wire is the negative and the **RED** wire is the positive.

2. Memory

The unit can hold up to 1600 authorized users and up to 400 limited users, total of 2000 users. The authorized 2000 phone numbers can open the gate at any time and any day. The 400 restricted users are limited to open the gate on certain days of the week and at a certain time interval of the day. The system will not answer any calls and hang-up on all incoming calls.

3. Output

The **White** and **Blue** wires are the internal relay's connections; Normally Open (N.O.) & Com. You can select Normally Close (N.C.) contact instead of the N.O. contact of the internal relay by the external jumper in the unit. (See drawing above).

Please Note!

- The caller's ID of the users must be ON (not private) in order for the CellOpener-365 unit to identify the user when calling the system to gain access.
- For solar applications, to reduce the current consumption of the unit, you can remove the jumper link on the right-hand side in the unit, to turn off the LEDs after the installation is complete. See diagram above.

Programming

Please make sure that the mobile phone you are using to program this unit has its **Caller ID ON**.

Follow the instructions below to program the unit by SMS as per instructions below:

1. Adding & Deleting Phone Numbers

You can program and add up to 1600 phone numbers to be as normal users by sending SMS. The example below shows how to add 2 phone numbers and delete one phone number by SMS:

```
9999AN.12167315263.12168655002.DE.13302345678
```

- 9999 Is the password (default password 9999)
- AN Add the following normal number(s).
- DE Delete the following normal number(s).
- The dot marks the end of a number or command.

**Note: There is no need for the dot "." at the end of the SMS command.*

The maximum phone numbers are 5 phone numbers that can be added or deleted by one SMS command.

The unit should reply by SMS that says:

```
Confirming: 12167315263.12168655002 added, 13302345678 deleted.
```

The unit will disregard any phone numbers that were listed and could not be found in the system memory of the unit.

2. Deleting All of the Phone Numbers

To delete all the phone numbers, send the following SMS:

```
9999format
```

The unit will reply:

THIS IS A WARNING. Do you wish to DELETE all the phone numbers?

If you wish to proceed, confirm by sending "YES" in all capital letters:

YES

The unit will send back SMS that says:

All phone numbers were deleted

**Note: Ignoring the warning message and not replying "YES" within two minutes, will cause the unit to disregard the last command and the phone numbers would be saved and not be deleted.*

3. How to check the Unit's Current Internal Clock

To check the local time, date, and weekday in the system, send the following SMS:

9999clock

9999 Is the password (default password 9999)
clock current internal clock, date and weekdays report.

The unit will reply by SMS that says:

The local time is: HH:MM / DD.MM.YYYY, Weekday.

4. Adding or Deleting "Special Users"

You can program up to 400 phone numbers as "SPECIAL USERS". A "SPECIAL USER" is a phone number that has limited access during certain times of the day *and* is limited to access the property on special days of the week.

- a. The following SMS message is an example of how to allow an unlimited number of entries within a specific timeframe and on certain days of the week for a special user with the phone number 1(330) 831-7452 :

9999AS.13308317452.0.0900.1700.127

9999 Is the password (default password 9999)
AS Add Special number
13308317452 Is the phone number
0 To allow unlimited numbers of entries
0900.1700 To limit entries between 9:00AM to 17:00PM
127 Limiting access to Sundays(1), Mondays(2), & Saturdays(7)

The unit should reply by SMS that says:

Confirming: The number 13308317452 allowed unlimited entries on Sundays Mondays Saturdays between 9:00AM and 5:00PM

- b. The following SMS message is an example of how to allow a limited number of entries with no limit for times or days of the week for a special number:

9999AS.12168317435.3.0900.1700.1234567

9999	Is the password (default password 9999)
AS	Add Special number
12168317435	Is the phone number
3	Allow only 3 entries (0-99)
0900.1700	Limit the entries between 9:00AM to 17:00PM
1234567	Access for every day of the week

The unit should reply by SMS that says:

Confirming: The number 12168317435 allowed 3 entries on all days of the week between 9:00AM and 5:00PM

- c. The following SMS message is an example of a special user without time limit but with access limited to Sundays and Saturdays

9999AS.12168317435.3.0000.0000.17

9999	Is the password (default password 9999)
AS	Add Special number
12168317435	Is the phone number
3	Allow only 3 entries (0-99)
0000.0000	meaning <u>without time limit</u>
17	Access limited to Saturdays and Sundays

The unit should reply by SMS saying:

Confirming: The number 12168317435 is allowed 3 entries at any time on Sundays and Saturdays.

**Note: Please insert "0000.0000" for the time section if you do not want to limit the entries within any times*

5. How to choose the Relay's Function, Pulse or Latch

You can choose one out of two following functions for the internal relay:

MOMENTARY (PULSE)
LATCH function (ON / OFF).

The factory default setting for the relay is a MOMENTARY function (with a 1 second PULSE).

You can choose the required setting by SMS command as follows:

**Note: 9999 is the password (default password 9999)*

9999pulse01	For Momentary Function
9999latch	For Latch Function
9999function	For checking the current setting of the relay

The unit will reply accordingly to the above commands by SMS as follows:

Relay's function is: Momentary Pulse of 1 second

Relay's function is set for Latch function

If the unit is set for PULSE then:

The relay function is set to Pulse for 1 second

If the unit is set for LATCH then:

The relay is set to Latch Function

6. How to Set the Relay's Pulse Time

The factory default time setting for the relay is a Pulse of 1 second.

You can choose and set the PULSE time interval of the relays by SMS as follows:

9999pulse - -

The two hyphens " - - " after the word "pulse" represent the time in seconds up to 99 seconds.

Use the following commands to set the pulse time:

**9999 is the password (default password 9999)*

9999pulse00	for ½ a second pulse time.
9999pulse01	for 1 second pulse time (Factory Default)
9999pulse02	for 2 second pulse time

The unit will reply by SMS accordingly to the above as follows:

For example, send:

9999pulse00

The reply will be:

Relay's function is Momentary Pulse of ½ a second.

7. How to check if the Unit's Relay is ON or OFF

You can check the current status of unit's relay by SMS command as follows:

**Note: 9999 Is the password (default password 9999)*

9999relay

The unit will reply by SMS according to the current status of the relay.

If the relay is OFF the SMS reply would be:

The relay is OFF

If the relay is ON the SMS reply would be:

The relay is ON

8. How to check the GSM Reception Level

Send SMS:

**Note: 9999 Is the password (default password 9999)*

9999reception

The reception level of the GSM ranges from 0 to 5.

The unit will check the reception of the GSM network in the area and reply by SMS as follows:

The reception is 5

9. Automatic Learning of All Phone Numbers

The unit can be set to learn up to 1600 Normal Users automatically while the users call the unit to activate the relay. In this mode the unit checks the caller's ID (the mobile phone number) of each incoming call and registers it automatically in the system's memory and at the same time triggers the relay according to the chosen setting.

To activate the Automatic Learning send SMS:

9999automatic

To cancel the Automatic Learning send SMS:

9999manual

The unit will reply by SMS accordingly:

Automatic Learning mode is ON

or

Automatic Learning mode is OFF

10. How to check the Number of Users in the System

The system can be programmed with 1600 Normal Users and 400 Special Users. You can check the number of users in the system by sending SMS:

**Note: 9999 Is the password (default password 9999)*

9999users

The unit will reply by SMS:

There are #### normal users and ### special users in the system

11. How to LOCK / UNLOCK the system

The unit can be LOCKED, so that none of users can use the system and activate the relay.

To lock the system, send SMS:

**Note: 9999 Is the password (default password 9999)*

9999lock

To unlock the system, send SMS:

9999unlock

The unit will reply by SMS accordingly:

The unit is LOCKED

The unit is UNLOCKED

12. HOLD Command

The HOLD COMMAND enables you to overtake control of the system and keep the relay of the unit active (ON) until cancellation command is received. When the unit's relay is in HOLD mode, the unit will not respond to any other command until a cancellation command is received.

When the HOLD COMMAND is active ON, the unit will send SMS to each user that calls to trigger the gate to open saying:

Hold Command is Active

To activate the Hold Command send SMS as follows:

**Note: 9999 Is the password (default password 9999)*

9999hold

The unit will reply by SMS:

Hold Command is ON

To cancel the Hold Command send SMS as follows:

9999release

The unit will reply by SMS:

Hold Command is OFF

13. OPEN TO ALL Command

The unit can be programmed so that it will open the gate to ANY incoming call (without checking if the caller is an authorized user). You can activate or cancel this function by SMS command as follows:

To activate the OPEN TO ALL command, send SMS as follows:

**Note: 9999 Is the password (default password 9999)*

9999open

The unit will reply by SMS:

Open To All: is ON

To cancel OPEN TO ALL command, send SMS as follows:

9999close

The unit will reply by SMS:

Open To All: is OFF

14. How to set the unit to Factory Default Settings

To set the unit to "Factory Default Settings" means the unit will delete all the phone numbers and reset all the functions to factory default parameters as it was supplied initially. To set the unit to Factory Default you need to send the following SMS command:

**Note: 9999 Is the password (default password 9999)*

9999default

The unit will reply by SMS:

THIS IS A WARNING. Do you wish to DELETE all the phone numbers and set the unit to factory default ?

To proceed and factory reset the unit, you must confirm within 2 minutes by SMS in all capital letters:

YES

The unit will confirm by SMS:

The unit was set to factory default

**Note: Ignoring the warning message and not replying "YES" within two minutes, will cause the unit to disregard the defaulting command.*

15. How to change the Password

The factory default password is 9999 and it can be changed by sending the following SMS message where "####" correspond to the new password:

9999password####

The unit will confirm by SMS reply:

The new password is # # # #

16. INPUT – 1: Gate's Status

This input can be used to check the status of the gate and see if the gate is OPEN or CLOSE. This is done by connecting a magnetic read-switch to this input and to the ground. If this input is connected to the ground that means the GATE is CLOSED and if it is not connected to ground (open circuit) it means the gate is OPEN. To check the status of this input, send SMS command as follows:

**Note: 9999 is the password (default password 9999)*

9999status

The unit will reply by SMS accordingly.

If input-1 is connected to ground:

The gate is closed

If input-1 is open circuit:

The gate is open

17. How to customize the SMS message for INPUT – 1

You can customize the SMS message which the unit sends when input-1 is triggered to suit different applications.

You can program different messages by sending SMS message as follows:

9999RS.____ (Max 25 characters) _____.____ (Max 25 characters)____.

Example:

9999RS.The Alarm is ON.The Alarm is OFF.

9999 Default password
RS Status input-1
. Delineates between the functions

The NEW SMS reply message when the status input is connected to ground.

The Alarm is ON

The SMS reply message when the status input is not connected to ground.

The Alarm is OFF

18. INPUT - 2: Alert

This input can be used to ALERT someone on their mobile phone each time input-2 is triggered. This can be used as a DOORBELL or ALERT the user each time the gate opens. This can be done by connecting a push button as a doorbell or a read-switch to trigger when the gate opens and connect them to input-2 wire and ground. Each time this input is connected to the ground (triggered), the unit will send SMS message as is set in the system. The default message for this input is:

The gate was opened

You can program the phone number and different messages by sending SMS message as follows:

9999AL.(Phone number)____ (Message- max 25 characters)____.

The following is an example for programming the user's phone number and the message "Someone is at the gate"

9999AL.113308347235.Someone is at the gate.

9999 Default password.
AL Alert input
. Delineates between the functions
113308347235 The user's phone#
Someone is at the gate The SMS message when input-2 is triggered.

Programming Weekly & Yearly Timer

Weekly Timer

This smart system will automatically set its local time, day of the week and the date as soon as it is powered up. Moreover, it will also correct the local time in the unit when Daylight Time Savings occurs twice a year.

The weekly timer can be set to turn ON and OFF the internal relay on certain days and at certain time intervals. For example; to turn ON the relay at 7:00AM and turn it OFF at 17:00PM on each Monday and Saturday and to turn ON the relay at 9:00PM and turn it OFF at 11:00PM on each Tuesdays.

1. How to set the weekly timer

**Note: The weekly timer is limited to Max 2 different time intervals for each one of the weekdays.
For example: Mondays from 5:00AM till 10:00AM and from 05:00PM till 11:00PM.*

a. How to Set the Weekly Timer When There is Only ONE Time Event Per Day.

The following example shows how to set one time interval for each day of the week.
SMS message:

```
9999WT.0900.1700.127,0800.1300.345,0730.1500.6
```

9999	The default password for programming the unit is 9999
WT	Weekly Timer's events
0900	Starting time that the Weekly Timer will turn ON the relay: 09:00AM
1700	Stopping time that the Weekly Timer will turn OFF the relay: 17:00PM
127	Representing the days of the week: Sunday, Monday, and Saturday.
,	you must put a comma before the next command.
0800	The starting time is: 08:00AM
1300	The stopping Time is: 13:00PM
345	Representing the days of the week: Tuesday, Wednesday, and Thursday.
,	you must put a comma before the next command.
0730	The Starting time is: 07:30AM
1500	The Stopping time is: 15:00PM
6	Representing the day of the week: Friday.

The unit will confirm by SMS:

```
Weekly Timer ON: SUN, MON, SAT between 9:00AM and 17:00PM
```

TUE, WED, THU between 8:00AM and 13:00PM

FRI between 7:30AM and 15:00PM

That means: The relay of the weekly timer will turn ON at 09:00AM and turn OFF at 17:00PM on every Sunday, Monday, and Saturday. Also, it will turn ON at 08:00AM and turn OFF at 13:00PM each Tuesday, Wednesday and Thursday.

And turn ON at 07:30AM and OFF at 15:00PM each Friday.

**Note: The following SMS command is wrong: 9999WT.0900.1700.127,0800.1300.234,0730.1500.6
This is because the command contains two time intervals for MONDAY.*

b. How to Set the Weekly Timer for TWO Time Intervals Per Day

In order to set TWO time intervals for any day of the week, you would need to send TWO separate SMS commands. The first SMS command should be the same as in the previous example which needs to include the FIRST time interval of the day and the second SMS command should be for the SECOND time interval as is shown in the following example.

How to set: Monday to Friday from 8:00AM till 9:00AM *and* from 3:00PM till 4:00PM
and Saturday and Sunday from 8:00AM till 5:00PM

You would need to send two separate SMS commands as follows:

First SMS:

9999WT.0800.0900.23456,0800.1700.17

Second SMS:

9999WT2.1500.1600.23456

The unit will confirm by sending SMS with the settings registered in the system.

**Note: When the unit's relay is ON (active) by the weekly timer, the unit will not respond to incoming calls and will not*

trigger the relay for any user. Instead, the unit will send the following SMS message to the user that made the call:

"Your call was disregarded as the TIMER is ON at the moment"

** Note: The last SMS programming of the weekly timer will ALWAYS delete and overwrite the previous one.*

2. How to get the Weekly Timer Settings Report:

You can get the weekly timer's current settings and events by sending the following SMS:

9999WT.report

The unit will reply by SMS with all the time schedules in the system as in the example below:

No events are recorded for the Weekly Timer

Or for example:

The Weekly Timer is ON: Sunday, Monday, Saturday, between 9:00AM and 17:00PM

3. How to clear the settings of Weekly Timer:

Send SMS:

9999WT.clear

The unit will delete the current settings of the weekly timer and reply by SMS message as follows:

No events are recorded for the Weekly Timer

Yearly Timer

The Yearly Timer can be programmed to overtake control of the weekly timer and turn ON or OFF the relay output on certain days at certain times. For example:

To turn OFF the relay on 1st of September 2021 from 7:00AM until 13:00PM the next day.

This feature is very useful for setting public holidays and special events without the need of accessing the unit on site.

**Note: The Yearly Timer commands will override any Weekly Timer settings, if any was set for that day and time.*

1. How to set the Yearly Timer

The following SMS message is an example of how to set the yearly timer:

9999YT.010921.0700.020921.1300.OFF

9999	The default password 9999
YT	setting the Yearly Timer
010921	DDMMYY starting date: 1st Sep. 2021
0700	The time that the Yearly Timer will take control over the weekly timer is to be 07:00AM
020921	DDMMYY Ending date: 2nd Sep. 2021
1300	The time when the yearly timer finishes taking control over the weekly timer is 13:00PM

OFF The yearly timer will take control of the weekly timer and set the relay to OFF during the above days and time interval.

The unit will reply by SMS that says:

Confirming: Yearly Timer OFF: 01.09.21, from 07:00AM until 02.09.21 13:00PM

Another example:

9999YT.050122.0000.050122.2400.ON

The unit will reply by SMS that says:

Confirming: Yearly Timer ON: 05.01.22, 00:00AM until 05.01.22, 24:00PM

**Note: During the interval time when the relay is OFF (not active) the unit will respond to incoming calls of the users and will trigger the relay according to the setting.*

During the time interval when the relay is ON (active) the unit will not respond to incoming calls of the users, but it will send the users that call the unit SMS message saying: "Your call was disregarded as the TIMER is ON at the moment".

2. How to get All the Yearly Timer's Events that are registered in the system

You can get the Yearly Timer report of all the events by sending the following SMS:

9999YT.report

The unit will reply by SMS that says:

No events are recorded for the Yearly Timer

Or

The yearly timer is set for:21.05.18, 07:00AM till 21.05.18, 12:00PM, the system is ON

02.12.18, 00:00AM till 05.12.18, 24:00PM, the system is OFF.

**Note:*

- 1. The unit is limited to register up to 50 comments (events) for the yearly timer.*
- 2. Each SMS reply from the unit will include two events only, accordingly, the report from the Yearly Timer will be sent over by number of SMS messages as required.*
- 3. Each event and setting will be automatically deleted from the unit's memory, after the comment was executed and finished.*

3. How to Clear All the Yearly Timer's Settings & Events

Send SMS:

9999YT.clear

The unit will reply by SMS that says:

No events are recorded for the Yearly Timer

END.